



Friedhelm TRAPP GmbH

Ostring 15 - 63533 Mainhausen - Zentrale: 06182/9294-5 - Fax: 06182/9294-69 - Mail: trapp@f-trapp.de

www.f-trapp.de

Tree protection grid TBG-13/15

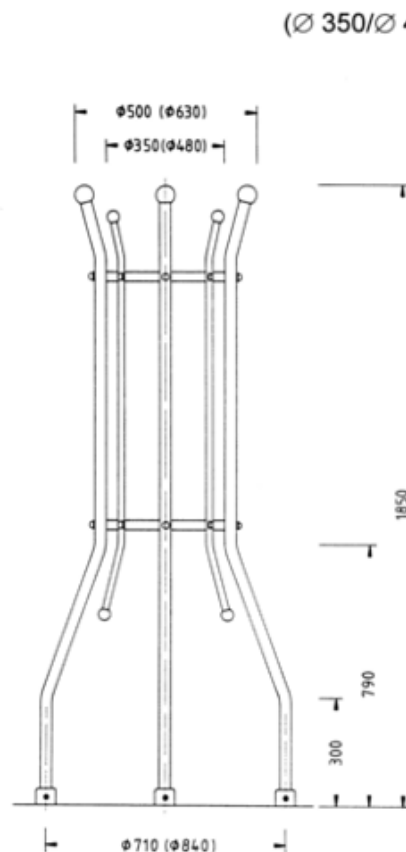

Technical description

Tree protection grid Consisting of 2 screwable separate segments for installation on TripIt or base stones.

(Precast concrete products are not scope of delivery)

Material:

Steel pipe and steel profiles, hot-galvanized and screwed All fasteners made of V2A.

Coating:

2 times paint, top coat RAL color choice

Weight, incl. bordering:

approx. 30 kg / 32 kg

Base:

Precast concrete made from reinforced concrete , wall thickness 150 mm, height 250 mm, available as an accessory.



Friedhelm TRAPP GmbH

Ostring 15 - 63533 Mainhausen - Zentrale: 06182/9294-5 - Fax: 06182/9294-69 - Mail: trapp@f-trapp.de

www.f-trapp.de

Tree protection grid TBG-20

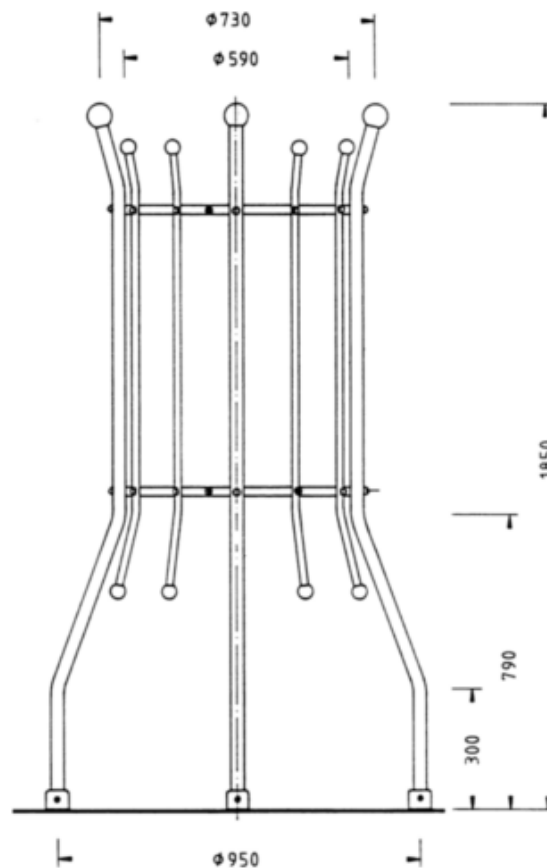

Technical description

Tree protection grid Consisting of 2 screwable separate segments for installation on TripIt or base stones.

(Precast concrete products are not scope of delivery)

Material:

Steel pipe and steel profiles, hot-galvanized and screwed All fasteners made of V2A.

Coating:

2 times paint, top coat RAL color choice

Weight, incl. bordering:

approx. 39 kg

base:

Precast concrete made from reinforced concrete , wall thickness 150 mm, height 250 mm, available as an accessory.



Friedhelm TRAPP GmbH

Ostring 15 - 63533 Mainhausen - Zentrale: 06182/9294-5 - Fax: 06182/9294-69 - Mail: trapp@f-trapp.de

www.f-trapp.de

Tree protection grid TBG-15/2

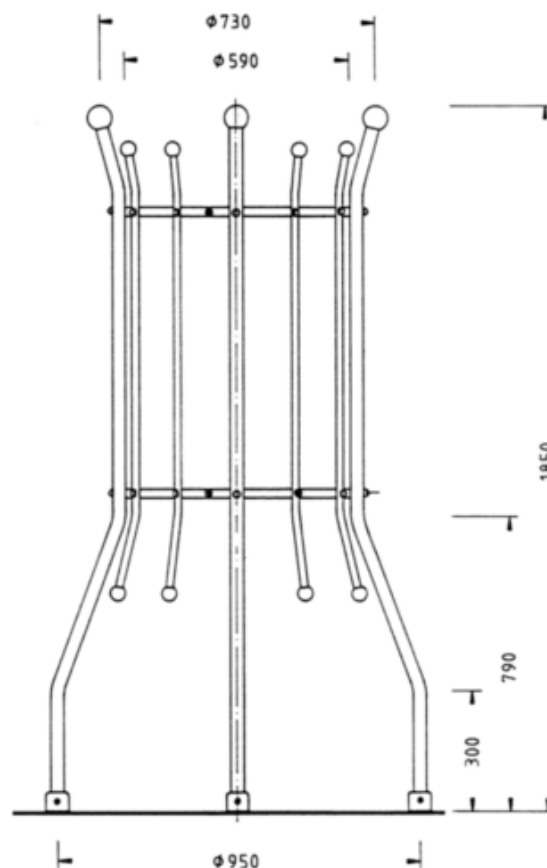

Technical description

Tree protection grid Consisting of 2 screwable separate segments for installation on TripIt or base stones.

(Precast concrete products are not scope of delivery)

Material:

Welded construction of steel profiles, mounting tabs made of cast iron, all parts hot dip galvanized.

Coating:

2 times paint, top coat RAL color choice

Weight, incl. bordering:

ca. 56 kg

Base:

Precast concrete made from reinforced concrete, wall thickness 150 mm, height 250 mm, available as an accessory.



Friedhelm TRAPP GmbH

Ostring 15 - 63533 Mainhausen - Zentrale: 06182/9294-5 - Fax: 06182/9294-69 - Mail: trapp@f-trapp.de

www.f-trapp.de

Tree protection grid example

